

SWITCHING REGULATOR APPLICATIONS

Features

- High Voltage: $BV_{DSS}=600V(\text{Min.})$
- Low C_{rSS} : $C_{rSS}=13.8pF(\text{Typ.})$
- Low gate charge : $Qg=41nC(\text{Typ.})$
- Low $R_{DS(on)}$: $R_{DS(on)}=0.65\Omega(\text{Max.})$

Ordering Information

Type NO.	Marking	Package Code
MF12N60	MF12N60	TO-220C-3L

PIN Connection

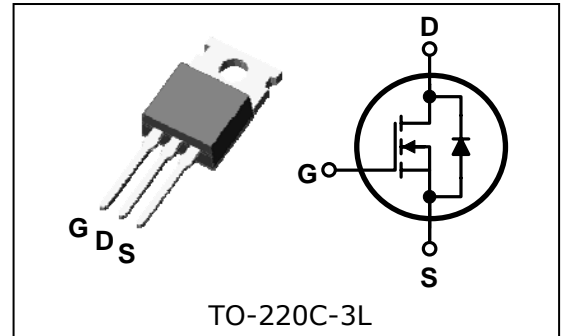

Outline Dimensions

unit : mm

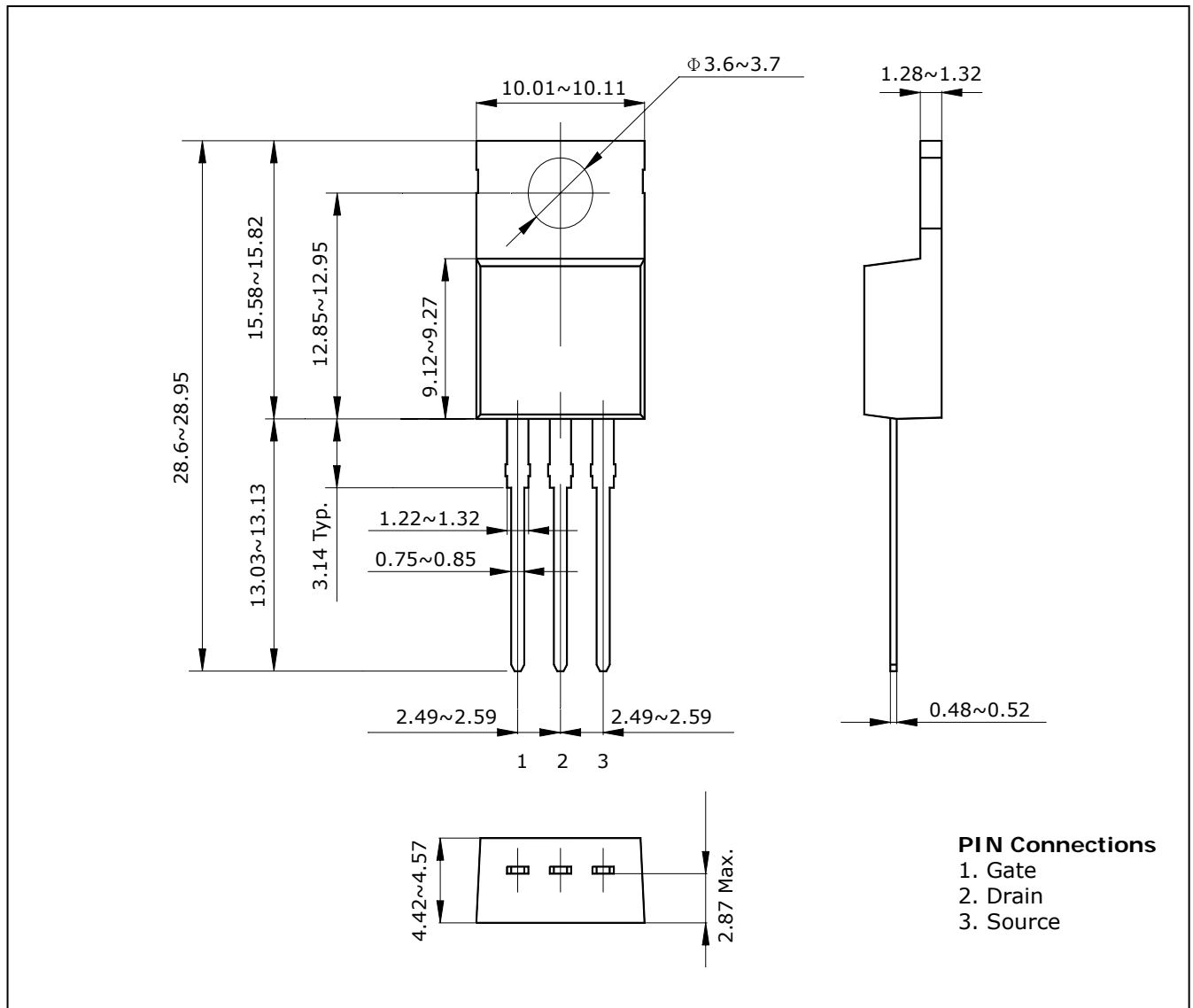

Absolute maximum ratings

(T_c=25°C)

Characteristic	Symbol	Rating	Unit	
Drain-source voltage	V _{DSS}	600	V	
Gate-source voltage	V _{GSS}	±30	V	
Drain current (DC)*	I _D	(T _c =25°C)	12	A
		(T _c =100°C)	7.1	A
Drain current (Pulsed)*	I _{DM}	48	A	
Drain power dissipation	P _D	210	W	
Avalanche current (Single) ②	I _{AS}	12	A	
Single pulsed avalanche energy ②	E _{AS}	700	mJ	
Avalanche current (Repetitive) ①	I _{AR}	12	A	
Repetitive avalanche energy ①	E _{AR}	11.6	mJ	
Junction temperature	T _J	150	°C	
Storage temperature range	T _{stg}	-55~150		

* Limited by maximum junction temperature

Characteristic		Symbol	Typ.	Max	Unit
Thermal resistance	Junction-case	R _{th(J-C)}	-	2.7	°C/W
	Junction-ambient	R _{th(J-a)}	-	62.5	

Electrical Characteristics

(Tc=25°C)

Characteristic	Symbol	Test Condition	Min.	Typ.	Max.	Unit	
Drain-source breakdown voltage	BV_{DSS}	$I_D=250\mu A, V_{GS}=0$	600	-	-	V	
Gate threshold voltage	$V_{GS(th)}$	$I_D=250\mu A, V_{DS}=V_{GS}$	2.0	-	4.0	V	
Drain-source cut-off current	I_{DSS}	$V_{DS}=600V, V_{GS}=0V$	-	-	1	μA	
Gate leakage current	I_{GSS}	$V_{DS}=0V, V_{GS}=\pm 30V$	-	-	± 100	nA	
Drain-source on-resistance ④	$R_{DS(ON)}$	$V_{GS}=10V, I_D=6.0A$	-	0.55	0.65	Ω	
Forward transfer conductance ④	g_{fs}	$V_{DS}=10V, I_D=6.0A$	-	10	-	S	
Input capacitance	C_{iss}	$V_{GS}=0V, V_{DS}=25V$ $f=1MHz$	-	2213	2951	pF	
Output capacitance	C_{oss}		-	170	226		
Reverse transfer capacitance	C_{rss}		-	13.8	18.4		
Turn-on delay time	$t_{d(on)}$	$V_{DD}=300V, I_D=12A$ $R_G=25\Omega$	-	30	-	ns	
Rise time	t_r		-	85	-		
Turn-off delay time	$t_{d(off)}$		③④	-	140		-
Fall time	t_f		-	90	-		
Total gate charge	Q_g	$V_{DS}=480V, V_{GS}=10V$ $I_D=12A$	-	41	63	nC	
Gate-source charge	Q_{gs}		-	13	-		
Gate-drain charge	Q_{gd}		③④	-	10.5		-

Source-Drain Diode Ratings and Characteristics

(Tc=25°C)

Characteristic	Symbol	Test Condition	Min	Typ	Max	Unit
Source current (DC)	I_S	Integral reverse diode in the MOSFET	-	-	12	A
Source current (Pulsed) ①	I_{SM}		-	-	48	
Forward voltage ④	V_{SD}	$V_{GS}=0V, I_S=12A$	-	-	1.4	V
Reverse recovery time	t_{rr}	$I_S=12A, V_{GS}=0,$ $di_S/dt=100A/\mu s$	-	500	-	ns
Reverse recovery charge	Q_{rr}		-	4.3	-	μC

Note ;

- ① Repetitive Rating : Pulse Width Limited by Maximum Junction Temperature
- ② $L=20mH, I_{AS}=8A, V_{DD}=50V, R_G=25\Omega$, Starting $T_J = 25^\circ C$
- ③ Pulse Test : Pulse Width < 300us, Duty cycle $\leq 2\%$
- ④ Essentially independent of operating temperature

Electrical Characteristic Curves

Fig. 1 $I_D - V_{DS}$

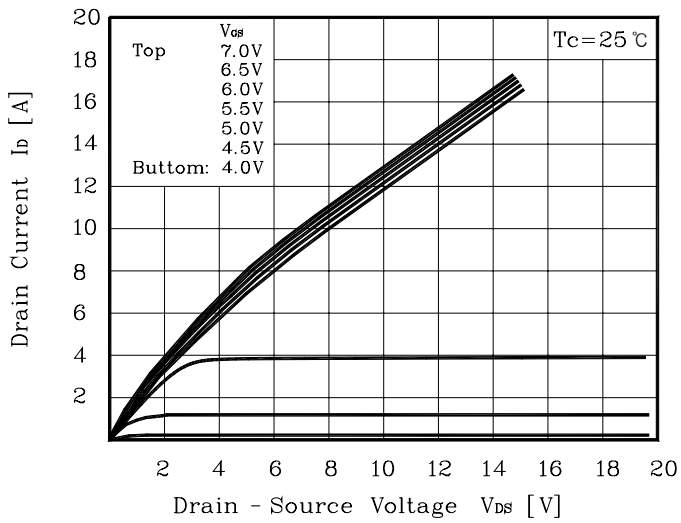

Fig. 2 $I_D - V_{GS}$

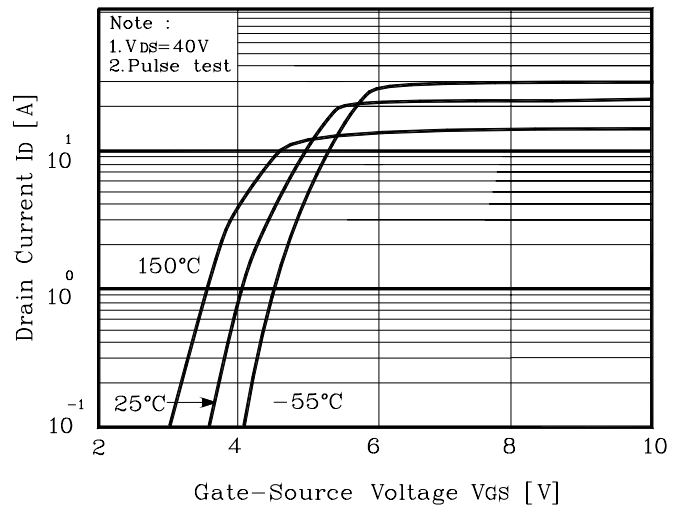

Fig. 3 $R_{DS(on)} - I_D$

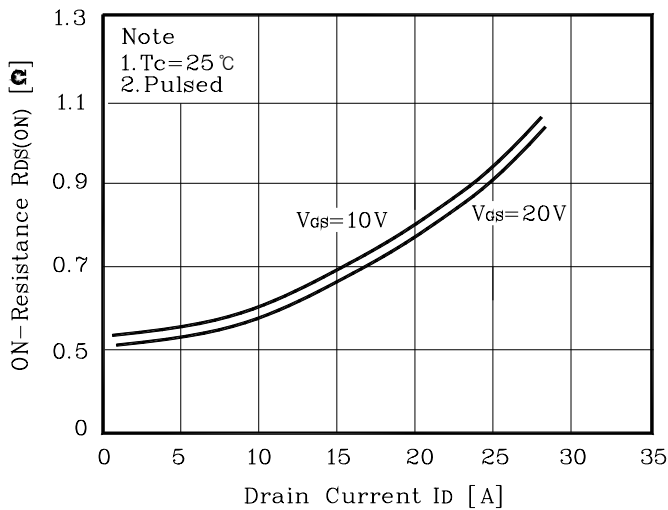

Fig. 4 $I_S - V_{SD}$

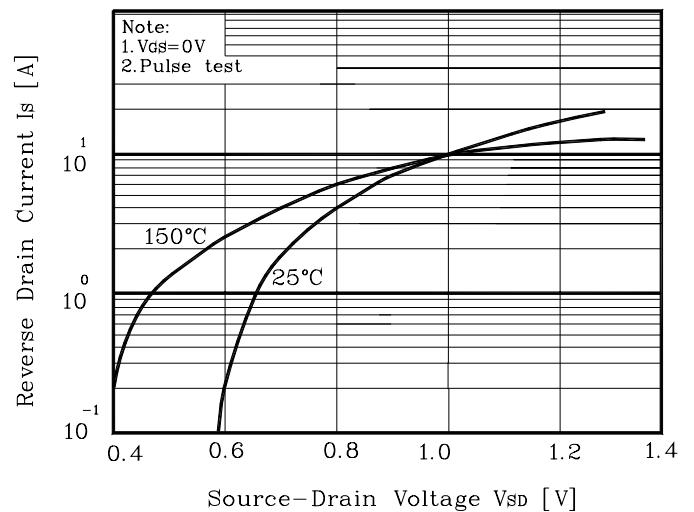

Fig. 5 Capacitance - V_{DS}

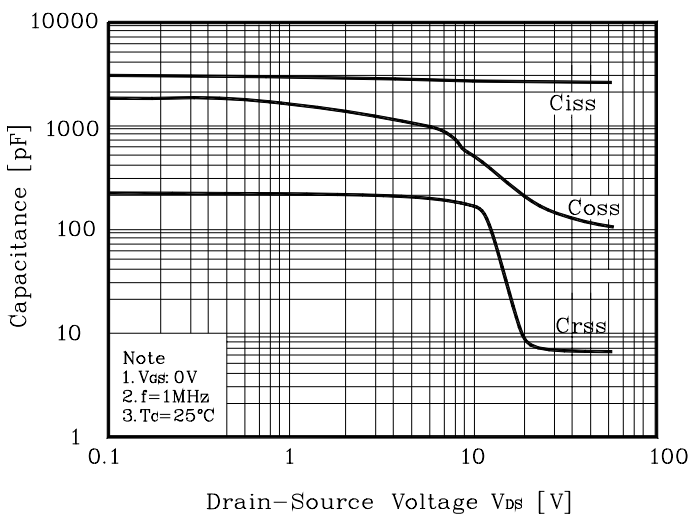
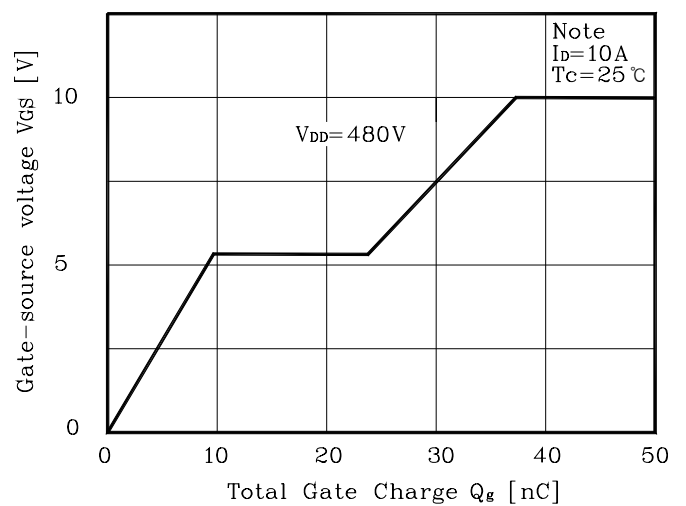

Fig. 6 $V_{GS} - Q_g$



Electrical Characteristic Curves

Fig. 7 $V_{DSS} - T_J$

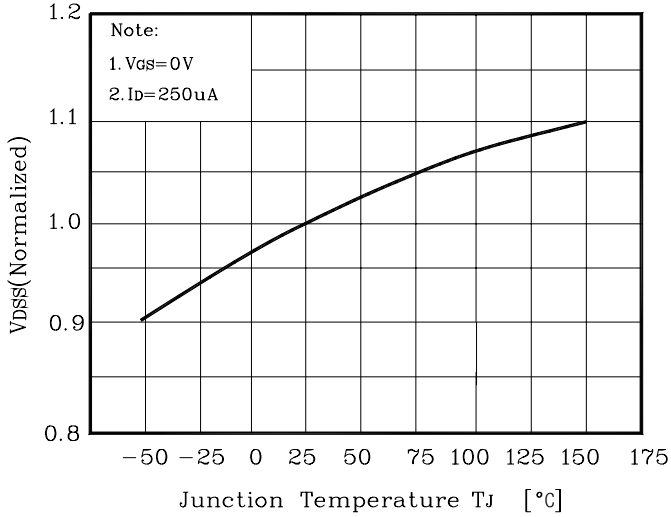

Fig.8 $R_{DS(on)} - T_J$

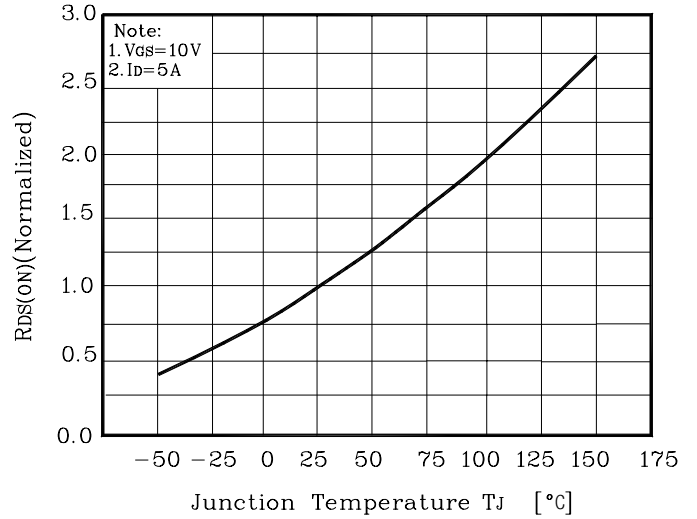

Fig. 9 $I_D - T_C$

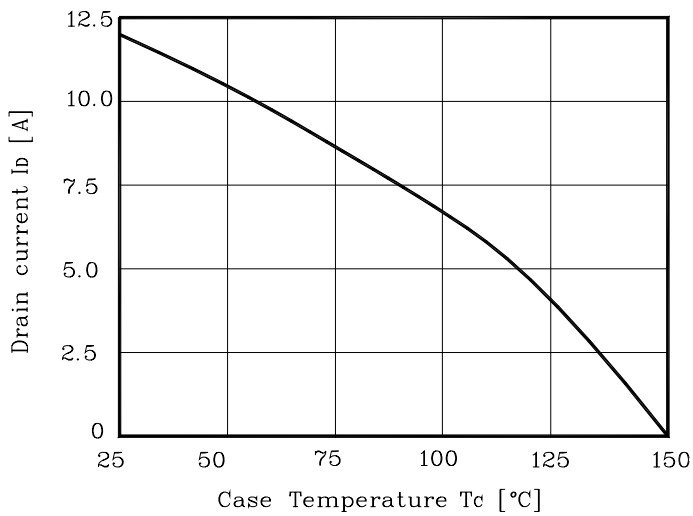

Fig. 10 Safe Operating Area

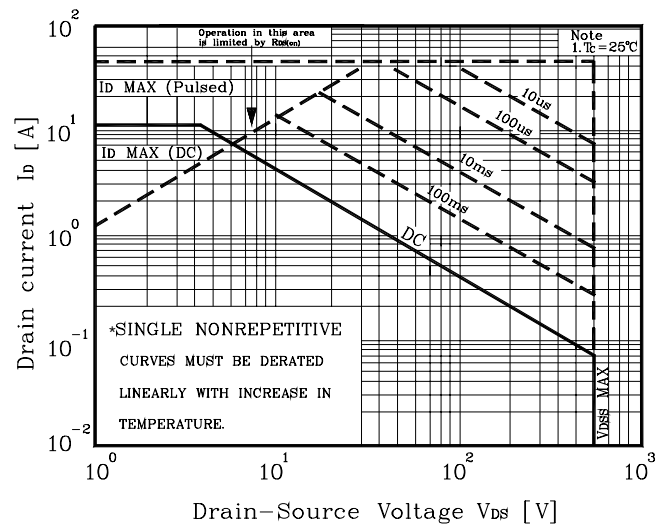

Fig. 10 Gate Charge Test Circuit & Waveform

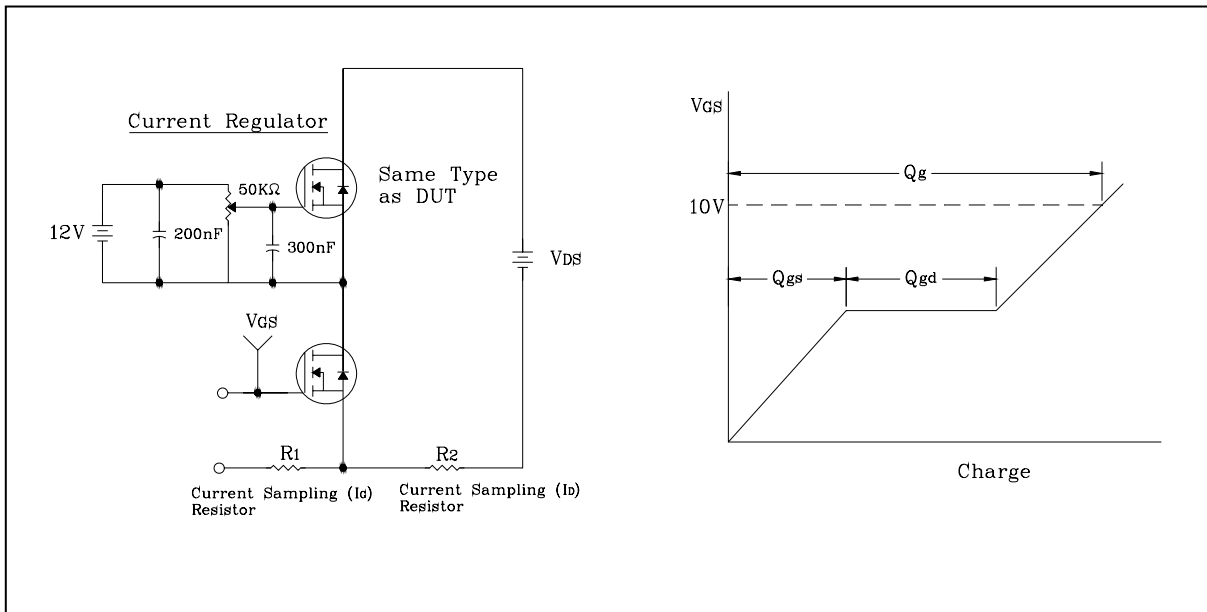

Fig. 11 Resistive Switching Test Circuit & Waveform

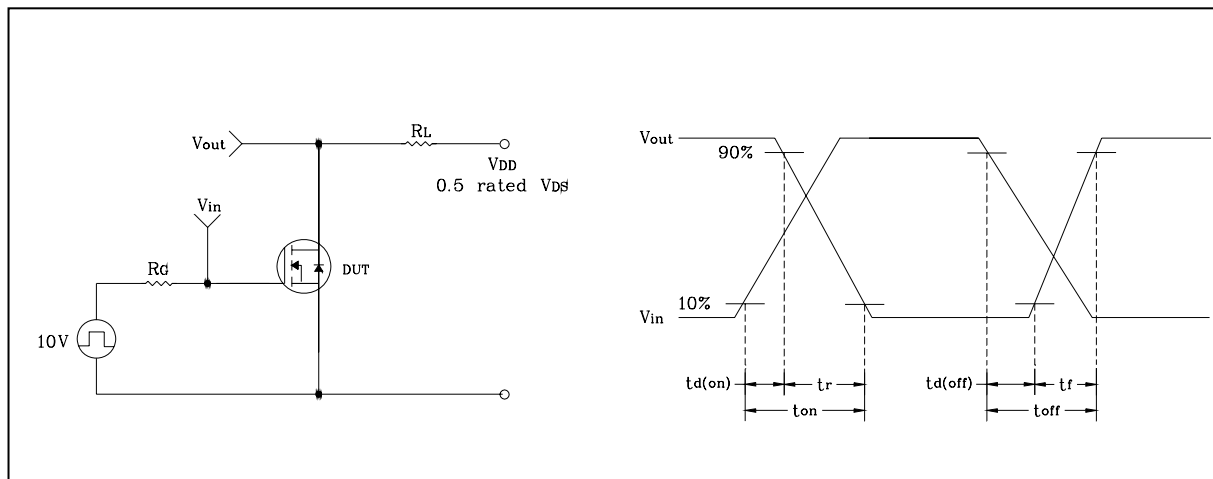

Fig. 12 E_{AS} Test Circuit & Waveform

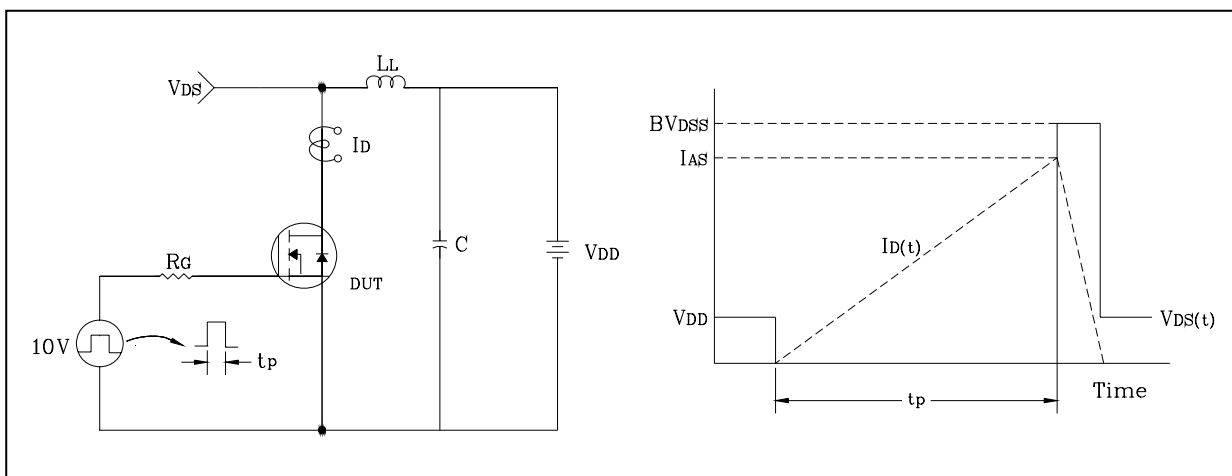

Fig. 13 Diode Reverse Recovery Time Test Circuit & Waveform

